**ÜRÜN KODU / Product code / Produkt kode****3200395983****ÜRÜN ADI / Product name / Produkt name****VIENA 65043 ORTA SEHPA****ÜRÜN EBADI / Product Size / Produkt Dimensionen****1100 x 630 x 295 mm****Bu modül iki kişi tarafından kurulmalıdır.**

This unit should be assembled by two persons.

Dieser artikel sollte von zwei personen montiert werden.

**Bu modülün kurulumu için gerekli olan araçlar.**

The necessary tools (not included)

Die dazu benötigten Werkzeuge (ausschliesslich)



Sayın Müşterimiz,

Satınalmış olduğunuz bu ürün sizlere ulaşmadan önce tarafımızdan her türlü kontrol ve testlere tabii tutulmuştur. Bu durumda bile taşıma sırasında bazı parçaların zarar görmesi mümkündür. Böyle bir durum ile karşılaşırsanız ürünün tamamını geri göndermeyiniz. Sadece zarar gören parçayı isteyiniz. Gerekli parçayı isterken ise servis kartına bakarak tam olarak tanımlayınız. Eksik olan parça en hızlı şekilde tarafınıza gönderilecektir.

Montaja başlamadan önce kutulardan çıkan tüm parça ve aksesuarları listelere göre kontrol ediniz. Parça ve aksesuarların tam ve sağlam olduğunu tespit ettikten sonra montaja başlayınız.

Montaja başlamadan önce her parçayı nemli bir bez ile temizleyiniz.

Eğer birden fazla ürün aldıysanız herhangi bir karışıklığa sebep vermeme için tek bir ürün montajını yaptıktan sonra diğer ürüne geçiniz.

Ürünleri hiçbir zaman sürterek taşımayınız. Ürünü kaldırarak ve sökerek en az iki kişi ile taşıyınız. Uzun mesafeli taşımalarda ürünü mutlaka paket ile taşıyınız.

Almış olduğunuz mobilyalarının yüzeylerinin temizlenmesi çok kolaydır. Nemli ve sabunlu bir bez ile veya diğer ev temizleyicileriyle silmek yeterlidir.

Mobilyalar aşırı sıcak, soğuk ve nemden etkilendiklerinden, mobilyanızı bu faktörlerle direkt olarak temas ettirmeyiniz.

Mobilyanızı amacı dışında kullanmayınız.

Dear Customer,

The product you bought was subjected to all sorts of tests and control before sending out to you. Even in this situation, sometimes happen that some component is damaged during the transportation. In such case please do not send the whole article back to us. Just request/order the damaged part. While requesting the required part, describe it exactly by looking to service card. Missing part will be sent to you as soon as possible.

Before start assembling, please check the whole components and accessories according to the lists. After being sure that every part and accessory are okay and right, start assembling.

Before start assembling, please clean all the components with a damp cloth.

If you bought more than one product, to prevent confusion be sure that you completed the first product. Then start the other product's assembling.

Never draw the products. While carrying, disassociate and lift the product and carry with minimum 2 people. For long distances carry the product with the package.

It is very easy to clean the surfaces of your product. It is enough to wipe with a damp and soapy cloth or other household cleaners. Do not directly contact your furniture with excessive heat, cold and humidity because the product can be affected.

Do not use your furniture for out of purposes.

Lieber Kunde,

das von Ihnen gekaufte Produkt durchläuft verschiedene Tests und Prüfungen bevor es zu Ihnen kommt. Trotzdem kann es vorkommen, dass während des Transports ein Teil beschädigt wird.

In solchem Fall bestellen Sie anhand der Servicekarte das beschädigte bzw. das fehlende Teil. Wir werden Ihre Anforderung sofort bearbeiten und Ihnen das Ersatzteil umgehend zusenden.

Kontrollieren Sie vor der Montage anhand der Zubehörliste alle Teile und Accessoires auf Vollständigkeit. Erst nach dieser Überprüfung können Sie mit der Montage beginnen.

Falls Sie mehr als ein Produkt gekauft haben, montieren Sie erst das eine und danach das andere Produkt, damit Sie mit den Teilen nicht durcheinander kommen.

Der Transport von fertig montierten Möbeln sollte immer von zwei Personen erfolgen.

**REINIGUNG**

Reinigen Sie die Teile mit einem leicht feuchten Tuch, danach trockenreiben. Keine scheuernden oder ätzenden Reinigungsmittel verwenden.

Hohe Hitze und Feuchtigkeit schaden Ihren Möbeln, bitte von diesen Quellen fernhalten.

Möbel bitte nicht zweckentfremden.

PARÇA LİSTESİ / Piece List / Stückliste				EBAT		
PARÇA NO	SAP KODU	PARÇA ADI	ADET	U	G	K
<b>2200271386 KUTU-1 VIENA 65043 ORTA SEHPA</b>						
1	2200271392	YAN PLAKA SAĞ	1	170	1100	18
2	2200271394	YAN PLAKA SOL	1	170	1100	18
3	2200172034	ÇEKMECE KASA SAĞ_350x75MM_KTN_VZN	1	350	75	12
4	2200172050	ÇEKMECE KASA SOL_350x75MM_KTN_VZN	1	350	75	12
5	2200271409	ÇEKMECE KASA ARKAL_554x75MM_KTN_VZN	1	554	75	12
<b>2200271380 KUTU-2 VIENA 65043 ORTA SEHPA</b>						
6	2200271388	ÜST PLAKA	1	596	729	18
7	2200271390	ALT PLAKA	1	596	729	18
8	2200271396	ARKA PLAKA	1	169	596	18
9	2200271398	ARA BÖLME	1	314	139	18
10	2200271400	ORTA PLAKA SAĞ	1	596	151	18
11	2200271402	ORTA PLAKA SOL	1	596	151	18
12	2200271404	ALT PLAKA DAR	1	596	351	18
13	2200271406	ÇEKMECE ÖNÜ	1	590	125	18
14	2200271408	ÇEKMECE ALTI	1	566	351	8
<b>2200271381 KUTU-3 VIENA 65043 ORTA SEHPA</b>						
	2200271387	AKS.POS. 65043 ORTA SEHPA				

PATLATILMIŞ PARÇA RESMİ

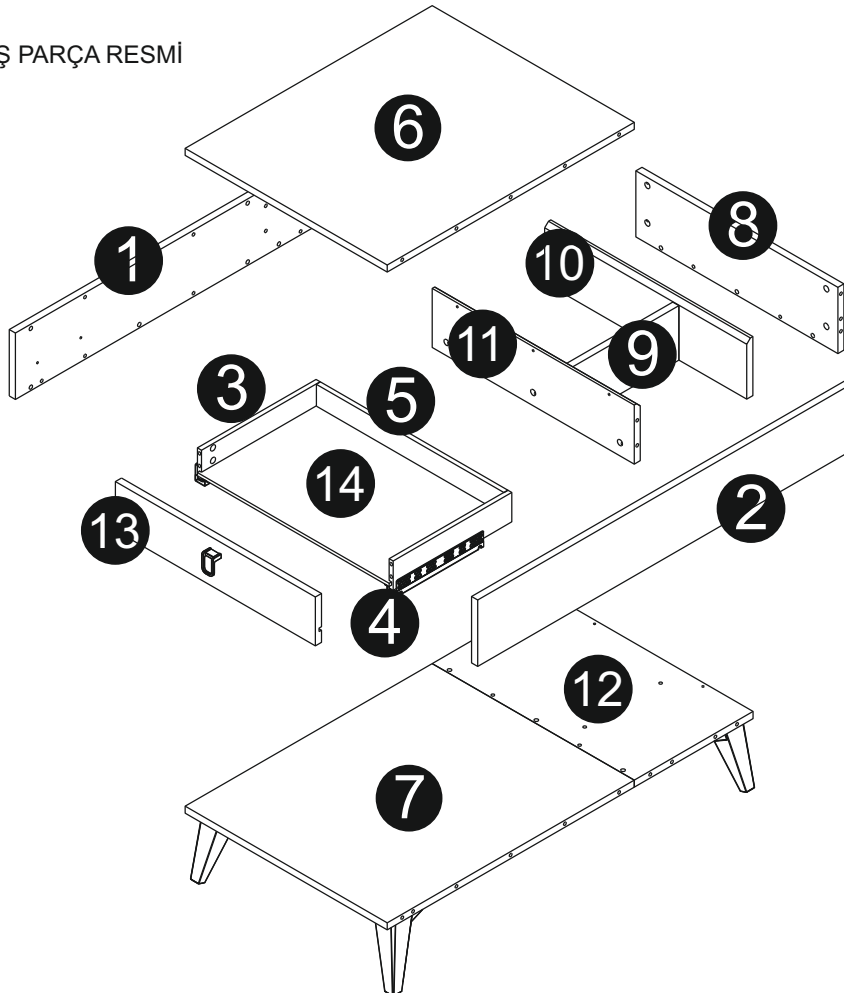

**AKSESUAR LİSTESİ / Accessory List / Zubehör Liste**

E68 MINİFİKS GÖVDE NİKL Ø15x13,2_1 1120007871 <b>33x</b>	A3 MINİFİKS KAFA RASTEX Ø12*10 1120020911 <b>4x</b>	E67 MINİFİKS MIL JETFIX Ø10X10_108 1120007870 <b>30x</b>	A12 KAVELA Ø8x30 MM PLASTİK 1100006324 <b>28x</b>	A49 EKSANTRİK KAPAK AMALFİ 1120006181 <b>12x</b>	A49 EKSANTRİK KAPAK METALIC İNCİ 1120037627 <b>7x</b>
E64 SLIDEA KISMI FRLİ 360 MM RAY 1100036921 <b>1x</b>	A16 VIDA YHB 6.3x14BEYAZ 1100006418 <b>4x</b>	A69 VIDA YHB 4x45 SUNTA 1100006394 <b>6x</b>	KLP1 MTK855_VIENA KULP 1120038207 <b>1x</b>	K12 VIDA YRB M4-23 1100006466 <b>2x</b>	PLS261 MENSAAAYAK 1120038155 <b>4x</b>
A39 Şeffaf arklık Plastik(Vidasız)-009700 1100016902 <b>4x</b>	A55 VIDA YHB 3.5x20 SUNTA 1100006387 <b>4x</b>	A64 VIDA YHB 5x30 SUNTA 1100006310 <b>12x</b>	A79 ETİKET KELEBEK PLAKET YAPIŞKAN 1100036449 <b>1x</b>	A8 MİL ÇİFTLİ EKZ. 68 MM 1100015035 <b>2x</b>	A38 VIDA YILDIZ BAŞLI KABİN Ø 6*50 1100006273 <b>4x</b>
E06 Minifix Mil Ø6,3*34 1120021323 <b>3x</b>					

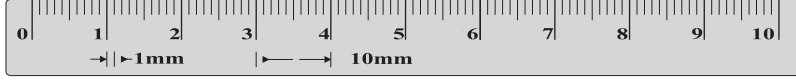

1

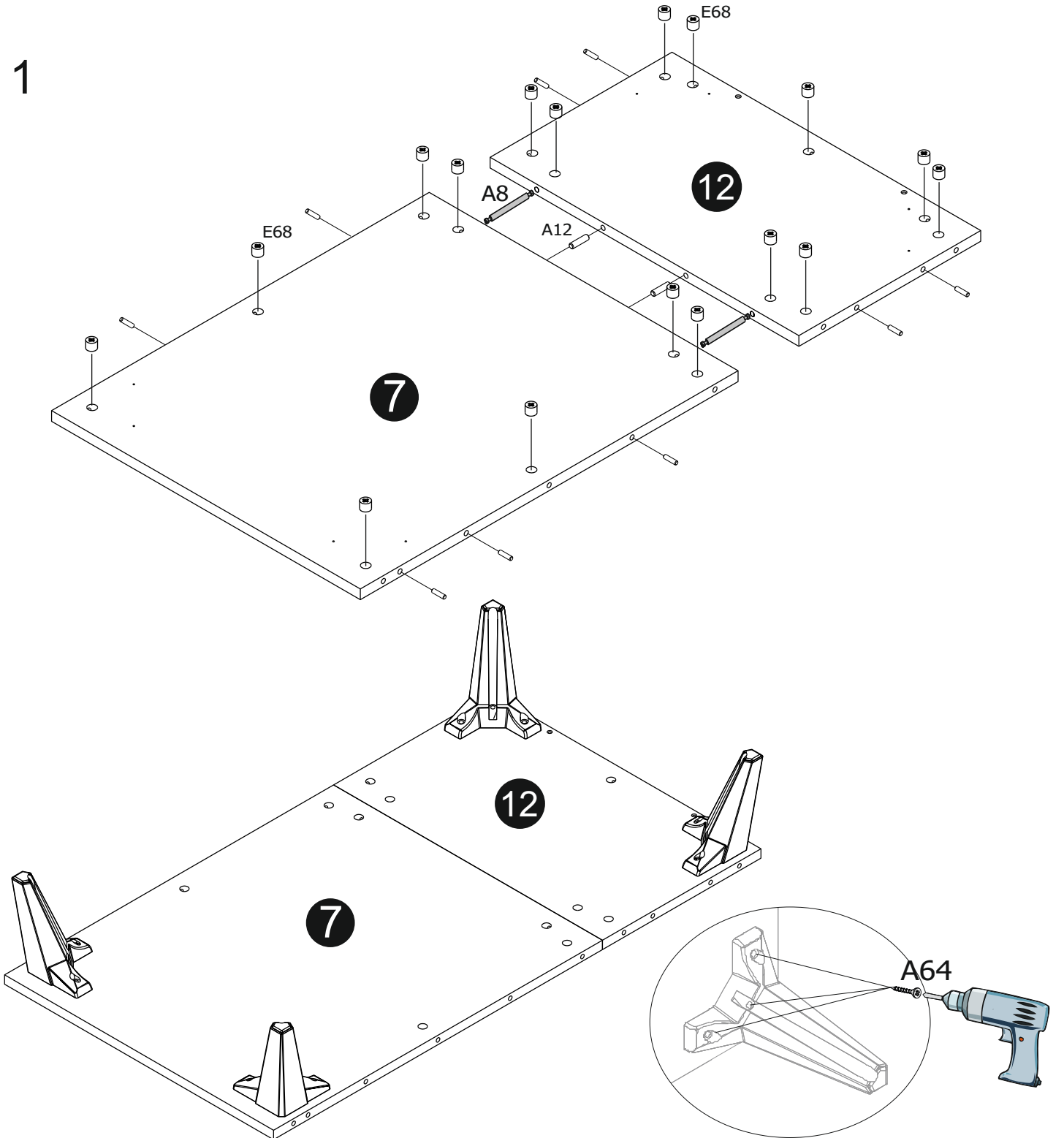

2

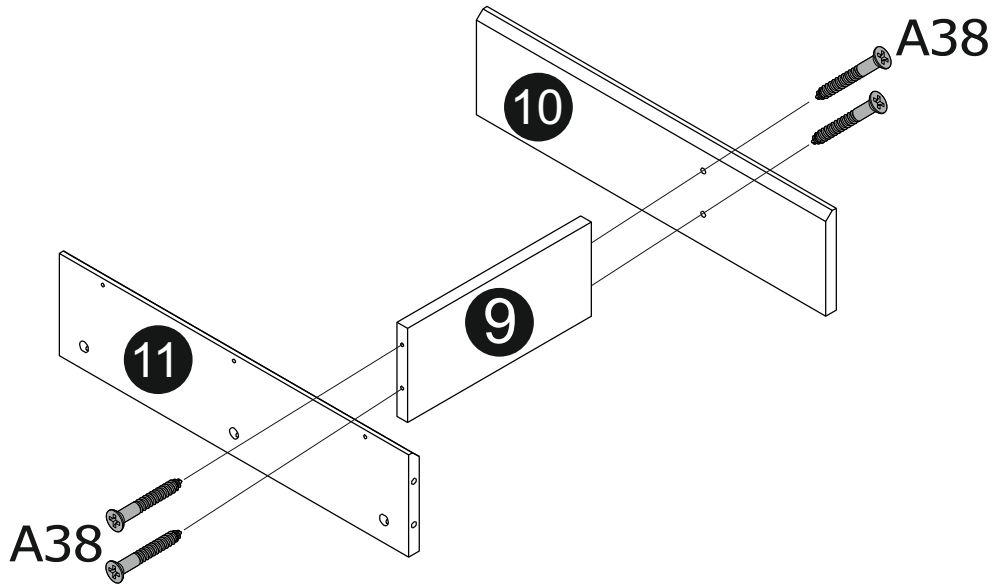
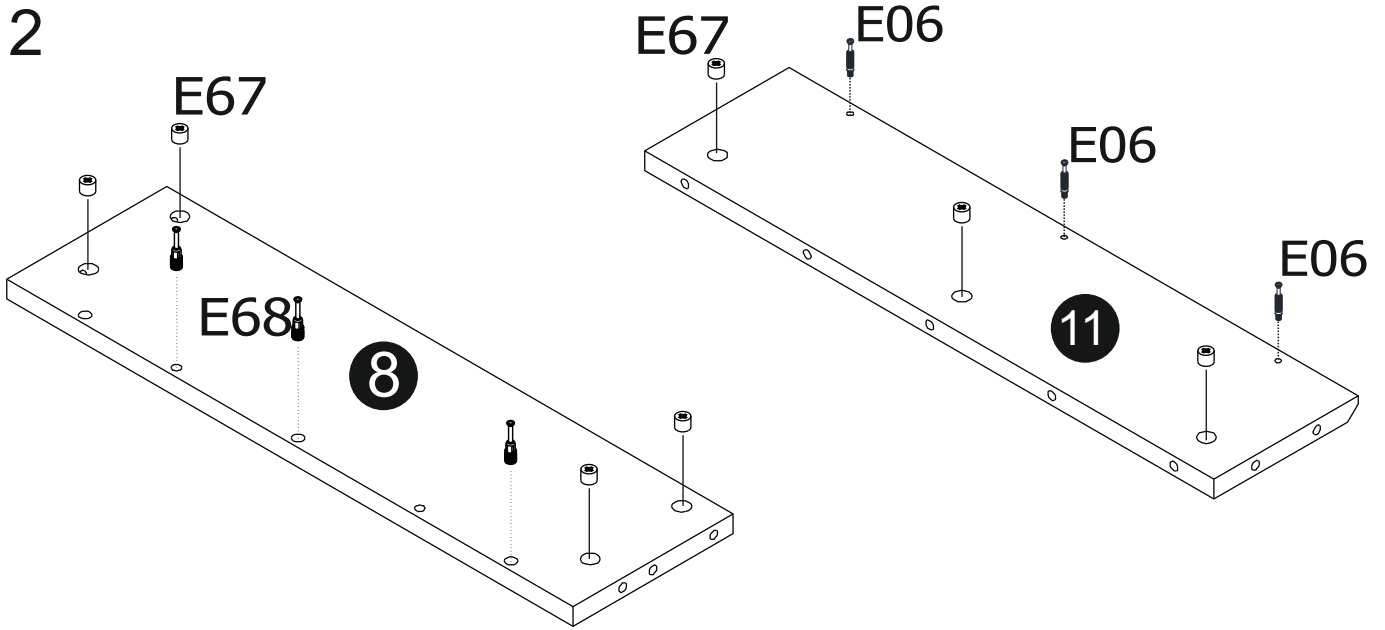

3

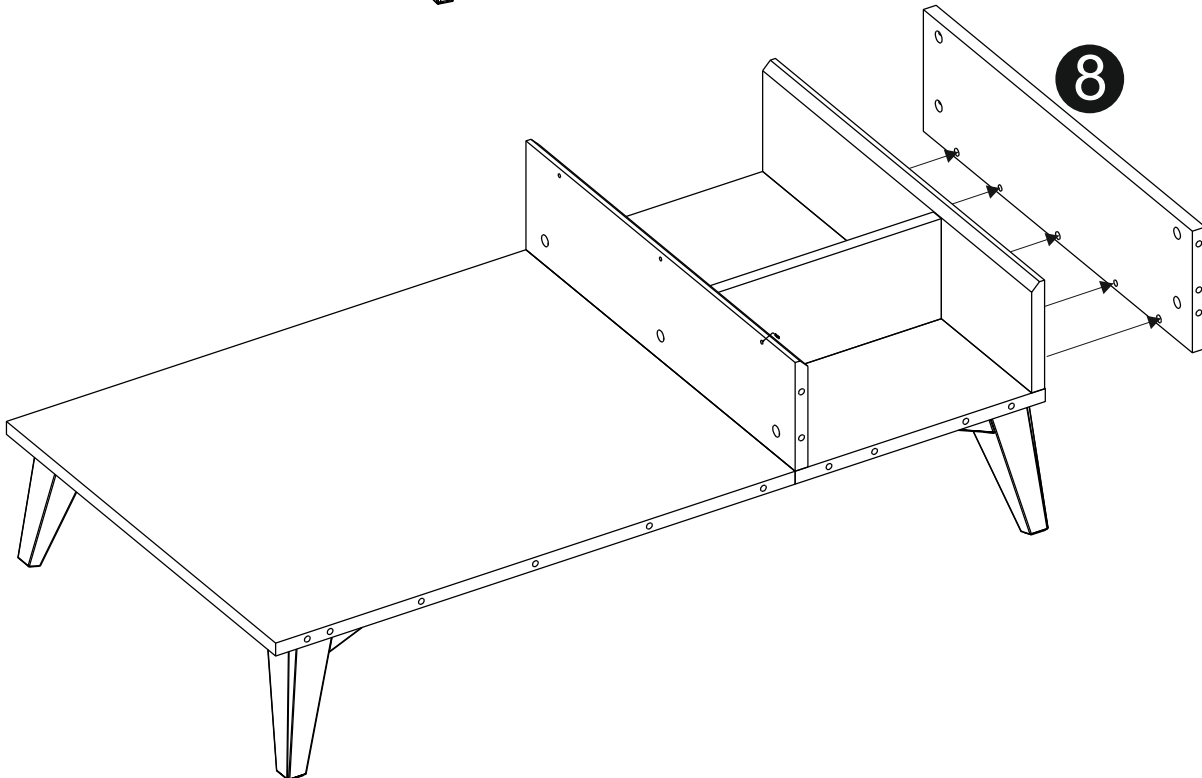
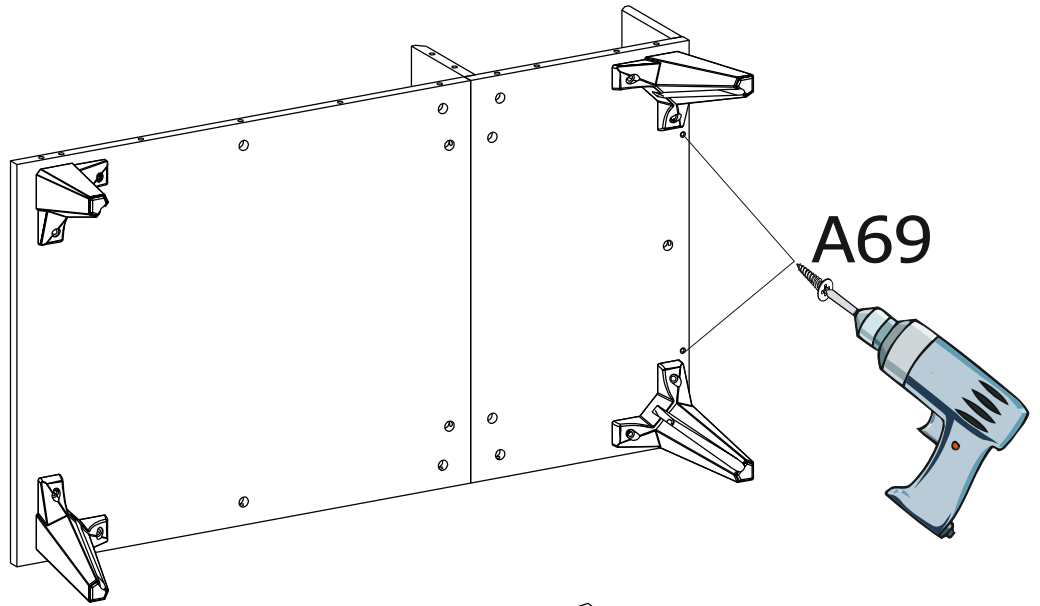
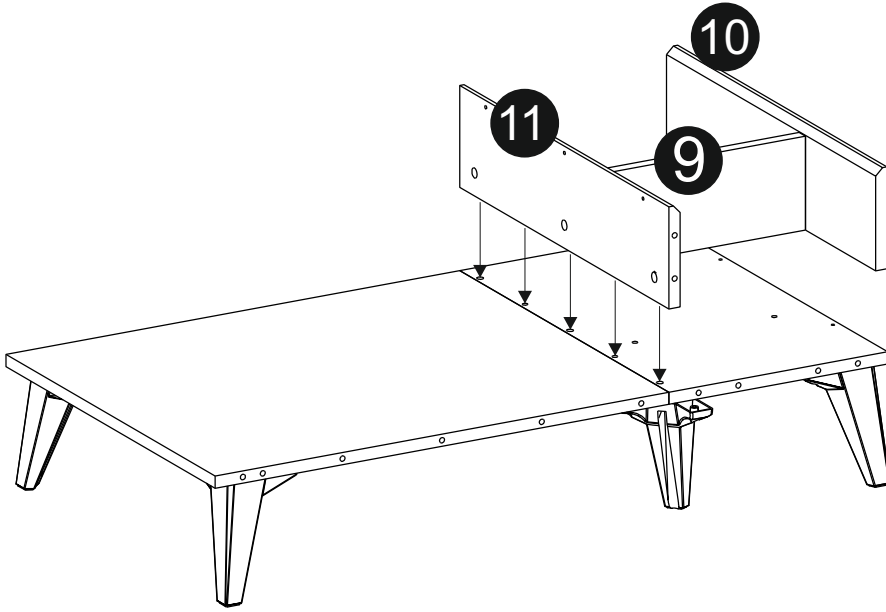

4

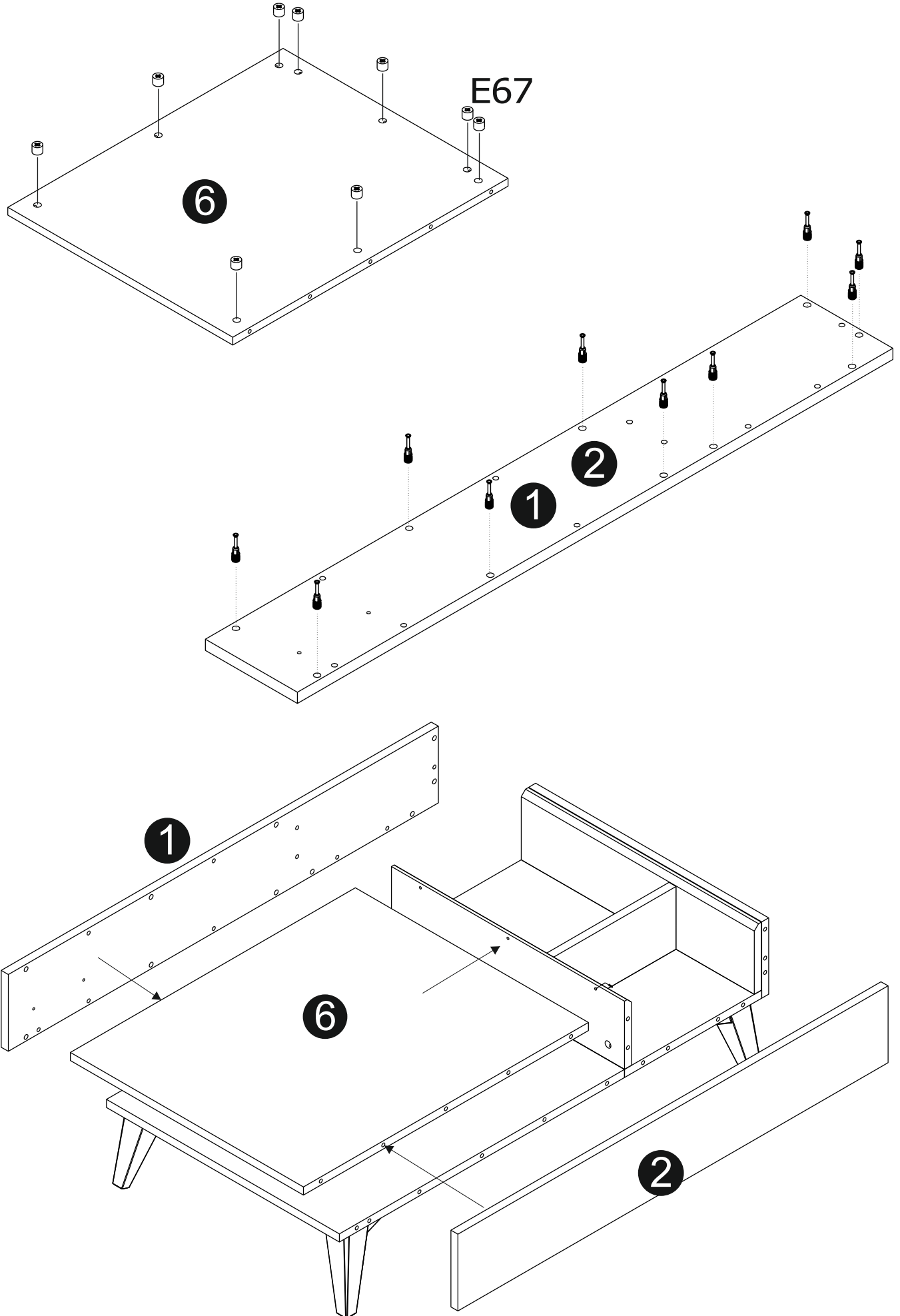

5

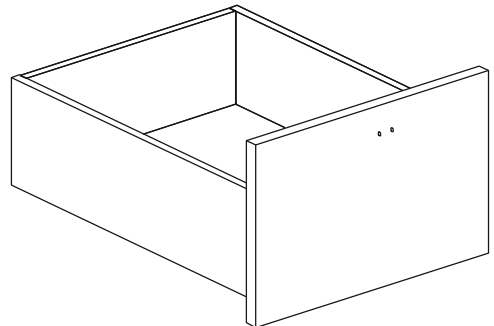
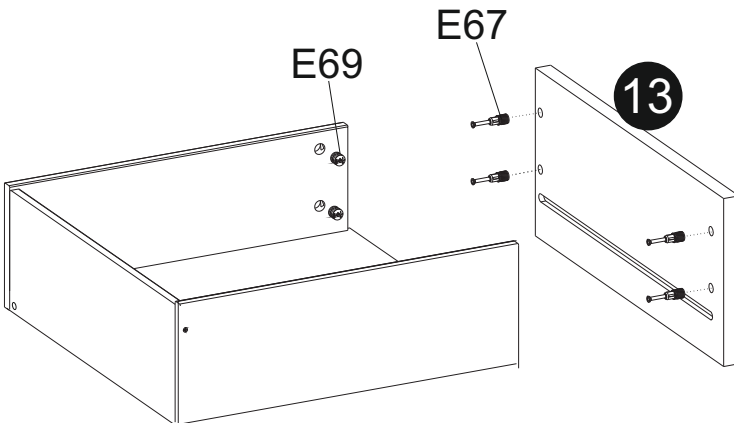
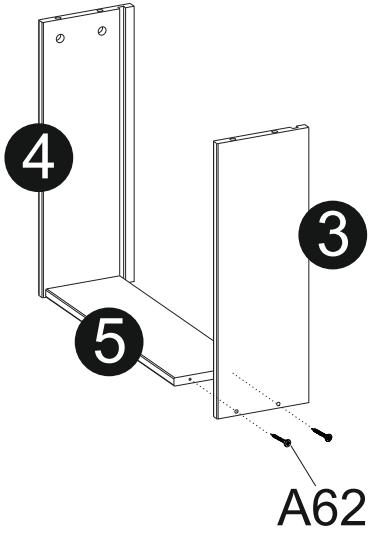
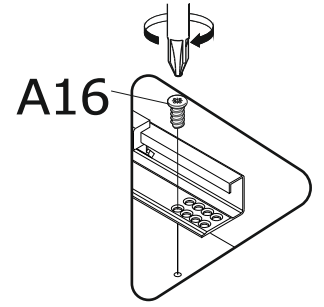
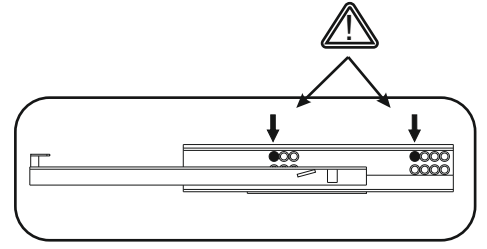
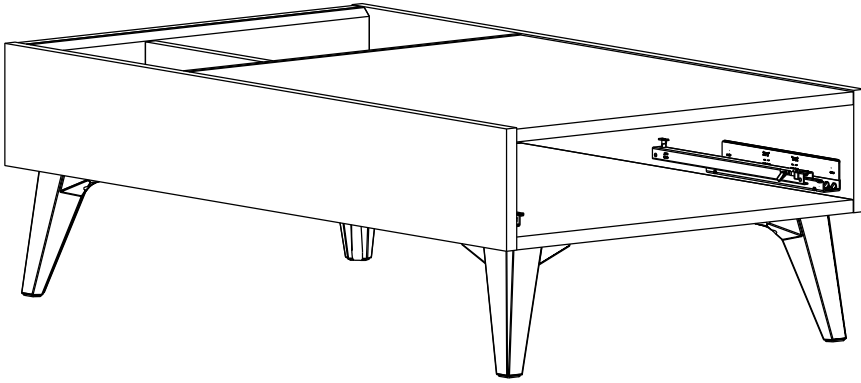

6

